

303 Power Amplifier
Instruction Book

Guarantee

This power amplifier is guaranteed against any defect in material and workmanship for a period of twelve months from the date of purchase.

Within this period we undertake to supply replacement parts free of charge provided that failure was not occasioned by misuse, accident or negligence. Labour and carriage costs are not covered unless by local agreement.

Within the U.K. the guarantee offered with this equipment does not limit the consumer's existing statutory rights.

Service

Normally the dealer supplying the equipment will be able to assist with advice or any attention the equipment may require but in case of difficulty you should return any Quad unit you wish to have checked, direct to our Service Department, or that of our main agent in the country concerned, carriage paid and preferably packed in its own original carton. If this is not available a pack will be forwarded on request.

Do not forget to enclose a note giving your name and address, full details of the reason for returning the unit and all the symptoms you have observed.

Acoustical Manufacturing Co Ltd
St Peters Road Huntingdon England
Telephone Huntingdon (0480) 52561

Contents

	Page
Connections	3
DIN Plug	3
Guarantee	1
Headphones	5
Initial Checks and Operation	5
Installation	3
Introduction	2
Loudspeakers	4
Mains	3
Service	1
Specifications	6

Illustrations

	Page
DIN plugs	3
Headphones	5
Installation Schematic	2
Mains connector	4

Introduction

This amplifier has been designed to provide the best possible quality of reproduction but it must be borne in mind that the standard of performance of the complete equipment will be limited by that of the poorest link in the chain. Thus, the gramophone motor, pickup, loudspeaker, etc., should all receive careful consideration if full advantage is to be taken of the capabilities of the amplifier.

A complete installation is shown in Fig. 1 and the same basic arrangement will apply in whole or in part, whatever associated equipment is used with the Quad 303. Installation is quite straightforward and should present no difficulty to the intelligent enthusiast provided the following notes are observed.

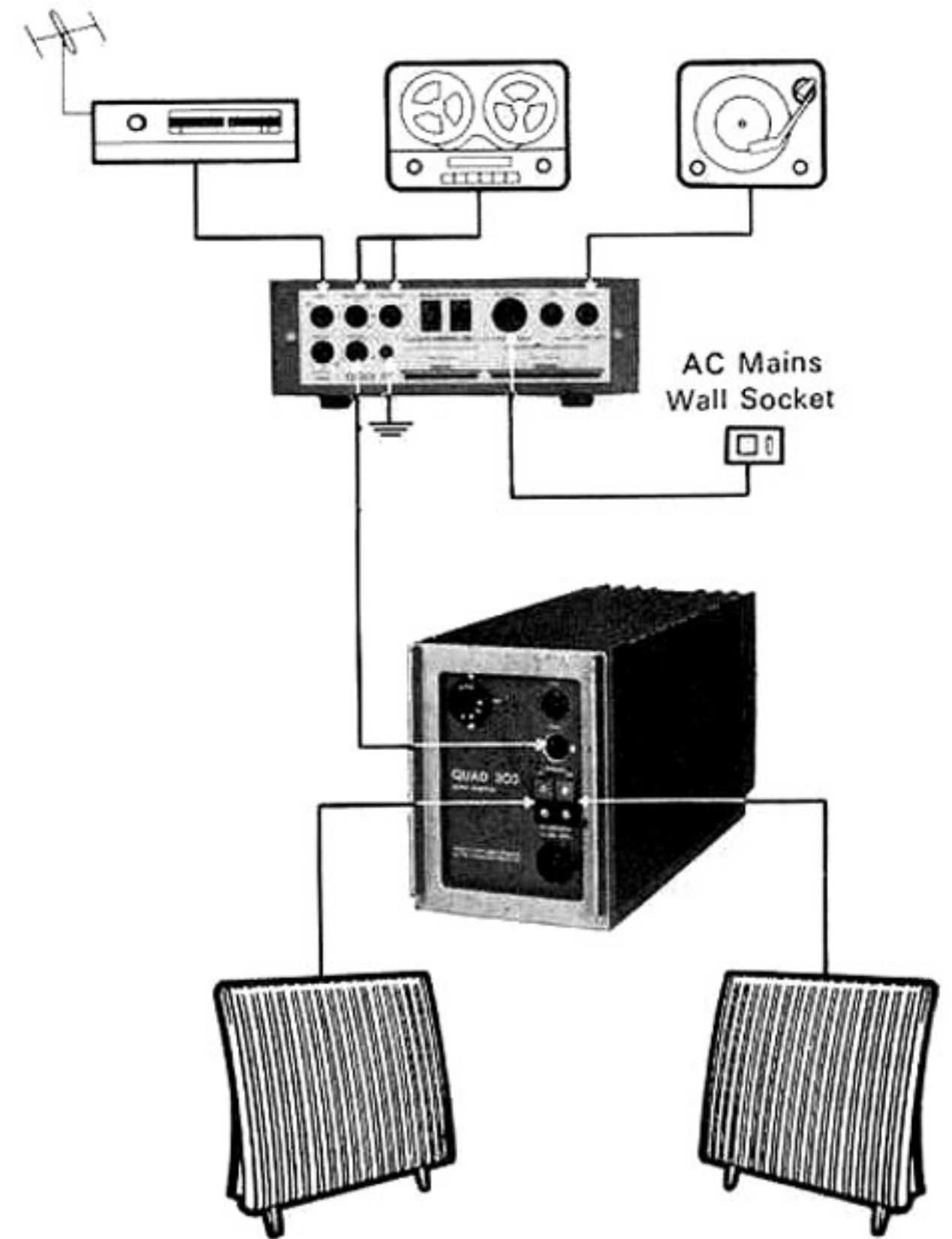

Fig. 1

Installation

Normally equipment of this type may be either mounted in a wide variety of housings or used free-standing, and if you are designing your own layout it might be advisable to assemble all the parts in a mock-up form before deciding on the final arrangement, just to make sure there are no unforeseen difficulties of operation or inter-unit wiring, etc.

Adequate ventilation must be provided for units producing heat, including transistorised power amplifiers and if the latter are to be mounted closer than about 12 inches from either control unit or tuner it might be necessary to experiment with orientation and position to ensure that no hum is induced in the latter units.

The Quad 303 carries no controls and may be mounted out of sight inside the cabinet or at any other convenient position in the installation.

The Quad 303 may be either stood on its feet on a shelf or base board of a cabinet, or more securely fixed by drilling four holes in the shelf or board to coincide with the feet centres, removing the feet securing screws and passing the longer screws provided, up through these holes, through the feet which act as spacers to assist circulation of air under the amplifier, and into the tapped bushes in the base-plate.

Slots or holes should be cut in or near the base and in or near the top of any enclosed compartment to permit a flow of air upwards through the compartment, past and through the amplifier to assist ventilation. In confined spaces where the exit vents are not directly over the amplifier a deflector plate of plywood or asbestos may be mounted at an inclined angle above the amplifier to help guide the rising warm air towards the exit vent and prevent an accumulation of warm air under a closed horizontal top.

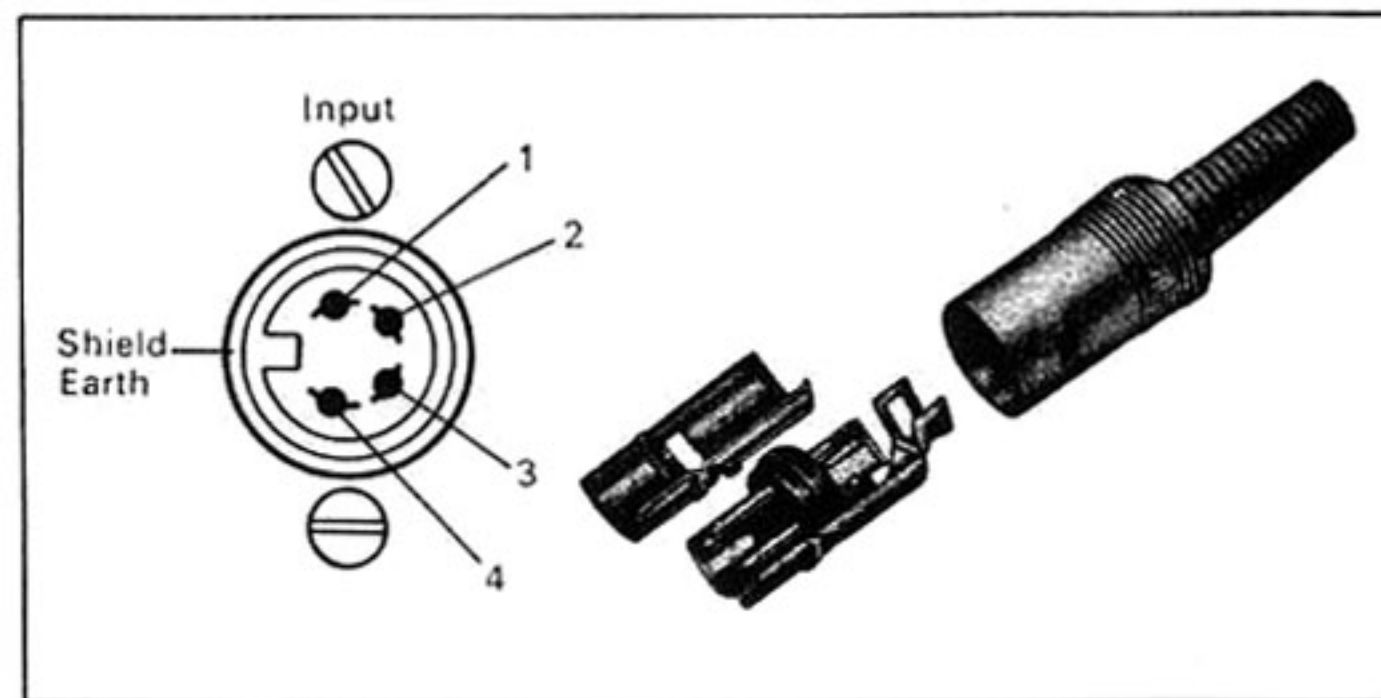

Fig. 2

Connections

Control Unit to Power Amplifier

A four-pin din plug and a mains connector are supplied for use when the amplifier is used without a Quad control unit, which provides these connections.

Viewed from the rear of the din plug the pins are numbered clockwise as shown in Fig. 2 and should be wired as follows:—

- | | |
|-------|---------------|
| Pin 1 | Left channel |
| 2 | Earth |
| 3 | Right channel |
| 4 | no connection |

The AC mains connector should be wired as Fig. 3 except where the signal source provides the earth, in which case the earth lead is omitted from this connector.

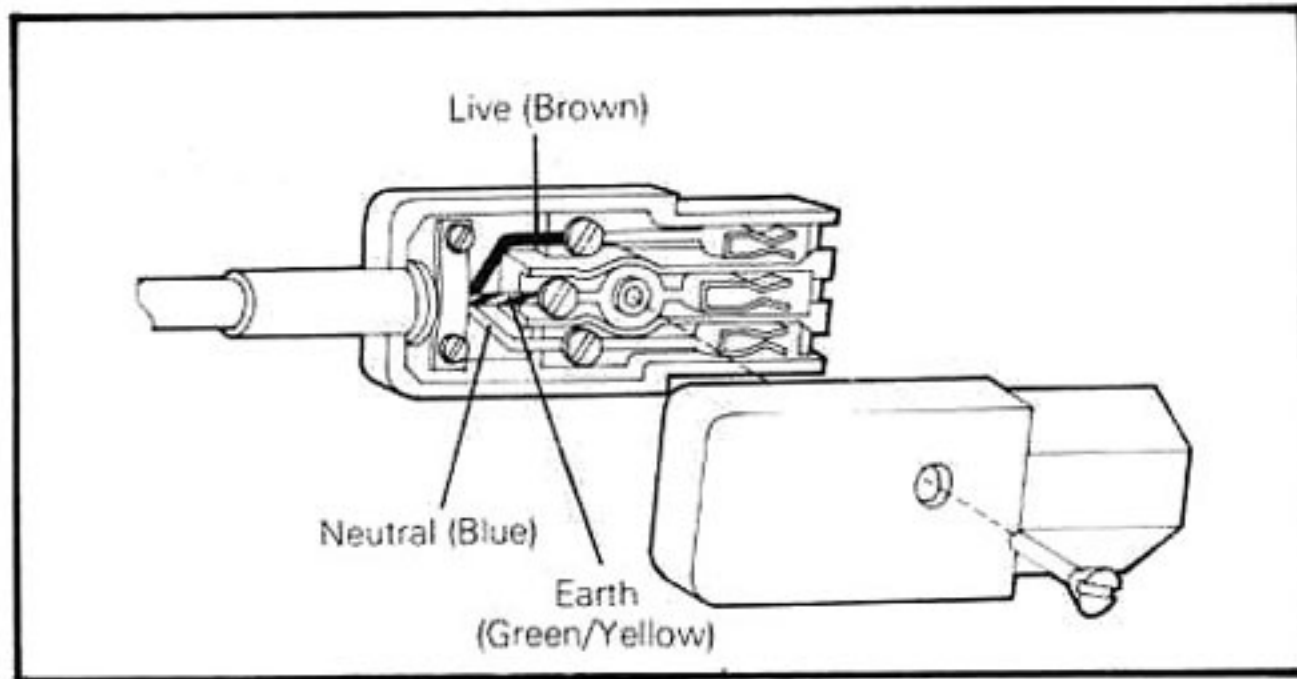

Fig. 3.

Ensure the mains selector corresponds with the voltage of your supply.

Note:

On amplifiers up to serial number 80500 a British 3 pin connector was used instead.

Power Amplifier to Loudspeakers

Ordinary lighting flex or similar cable may be used for connecting the loudspeakers to the power amplifier unless a very long run is involved in which case a heavier calibre cable should be used. As a rough guide the DC resistance of the cable should not exceed about 5% of the nominal impedance of the loudspeaker. Each loudspeaker should be connected to its appropriate power amplifier output so that the two pairs of wires are connected in the same way, to ensure that the speakers operate in phase. For example, if the top output socket on one channel is connected to the left-hand terminal of its speaker, the top output socket on the other channel should also be connected to the left-hand terminal of its speaker. This is quite straightforward but should there be any doubt the phasing can be checked later experimentally. Where one loudspeaker only is used for mono, phase is not important and in this case either outlet may be used and the sockets of the other channel left vacant.

In cases where loudspeakers, such as the electrostatic loudspeaker, also require an energising supply, the instructions provided with the loudspeaker should be followed. Each loudspeaker should be capable of handling the full output of the power amplifier.

The red output sockets must not be connected in parallel but a data sheet is available illustrating the recommended method of combining outputs if required.

Note:

Quad electrostatic loudspeakers prior to serial number 16800 (March, 1966) need slight modification before being used with the Quad 303 amplifier.

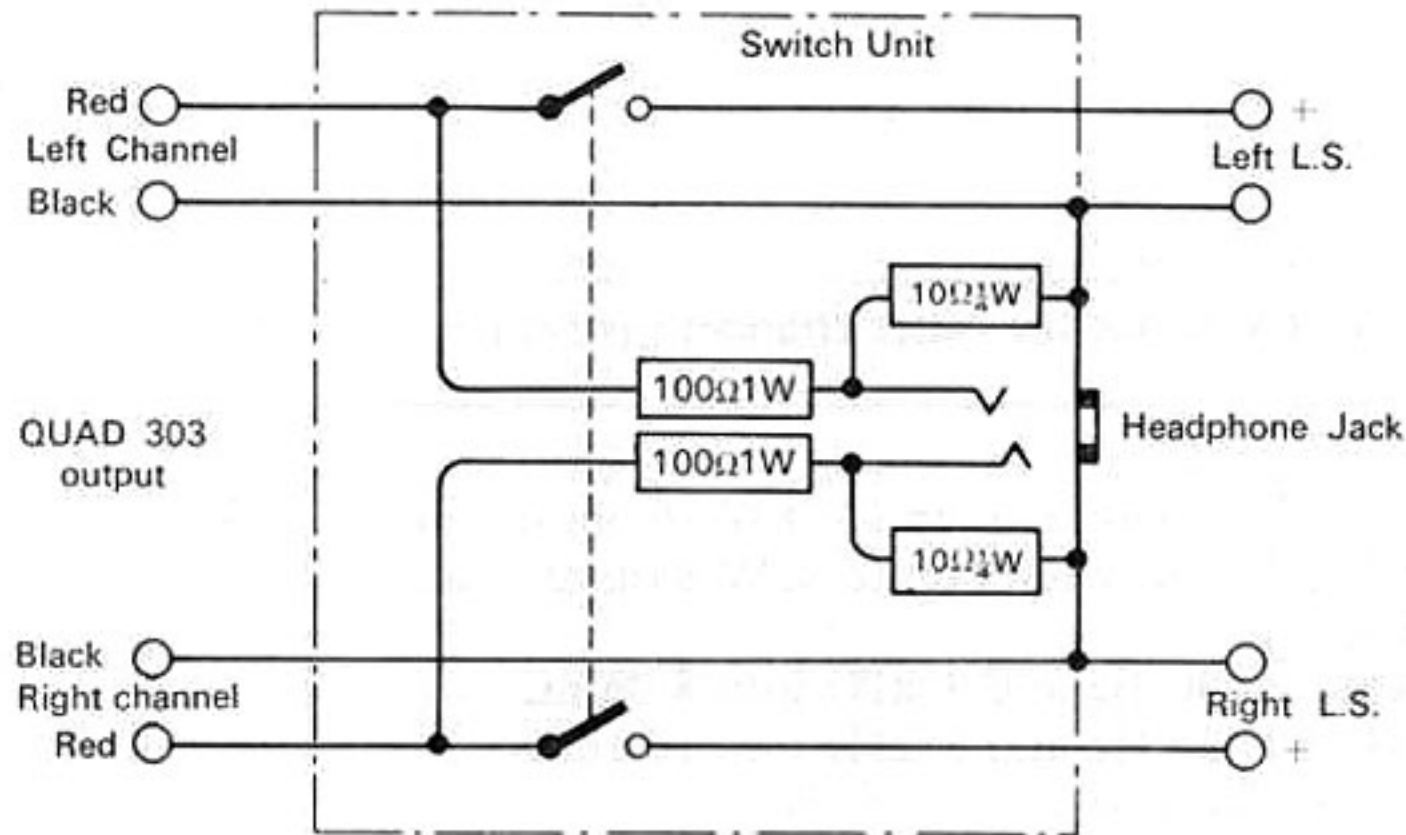

Fig. 4

Headphones

Headphones should be connected to the Quad 303 outputs in place of the loudspeakers and a typical wiring arrangement is shown in Fig. 3. Any of the headphone switch units on the market will provide the necessary switching and many of them also provide for incorporating the resistors which adjust the signal level to suit most magnetic headphones.

Electrostatic or other types requiring a high level input should be connected in accordance with the manufacturers' instructions.

The loudspeaker return leads (which may be commoned if necessary) must be taken to the black sockets and never to chassis or earth.

Initial Checks and Operation

Before connecting the mains supply, ensure that the voltage marked on the rear of the control unit, the adjustment on the tuner and the selector on the power amplifier are correct for your mains. This selector is set by withdrawing the cap $\frac{3}{8}$ " rotating it to the required voltage and pushing it fully home again. Then connect the mains and rotate the volume control to switch on the equipment. The Quad 303 indicator light should now light up.

The loudspeaker(s) should be tried in the various room positions which appear physically possible, in order to ascertain which positions are likely to be worth further investigation.

The loudspeaker should now be used in each of these positions for normal day to day listening. The usual attention should be paid to the programme itself without any conscious concentration on the quality. In this way the optimum position for most satisfactory listening will soon become apparent.

Specification for Quad 303 Power Amplifier

The figures and curves refer to measurements on either channel, with or without the other channel operating.

POWER OUTPUT AND DISTORTION:
(with unrestricted bandwidth)

70 Hz <0.03 %	} Any level up to 28W 16 ohms load
700 Hz <0.03 %	
10 kHz <0.1 %	

FREQUENCY RESPONSE:

—1dB (ref: 1kHz) at 30 Hz and 35kHz into 8 ohms.

—1dB (ref: 1kHz) at 20 Hz and 35kHz into 16 ohms

0.3 ohms in series with 2000 μ F and 6 μ H.

OUTPUT SOURCE IMPEDANCE:

INPUT LEVEL:

0.5 V rms for 30 watts into 16 ohms

INPUT IMPEDANCE:

22K ohms in parallel with 60pF

HUM AND NOISE:

—100dB below full output

INTERCHANNEL CROSSTALK:

30–10,000 Hz better than 60dB. Input load 1 K ohms.

STABILITY:

Unconditionally stable with any load.

POWER INPUT:

100–125 or 200–250 V 50–60 Hz.

40–200 watts depending on signal level.

WEIGHT:

18lb. (8.2Kg).

DIMENSIONS:

Width 120mm.

Height 159mm.

Depth 324mm.

(plus 38mm. for connectors).

OTHER APPLICATIONS:

For music in the home the amplifier is suitable for use with speakers of all impedances between 4 and 25 ohms. For high level sine-wave duty and other special applications involving reactive loads the load impedance should be not less than 8 ohms.

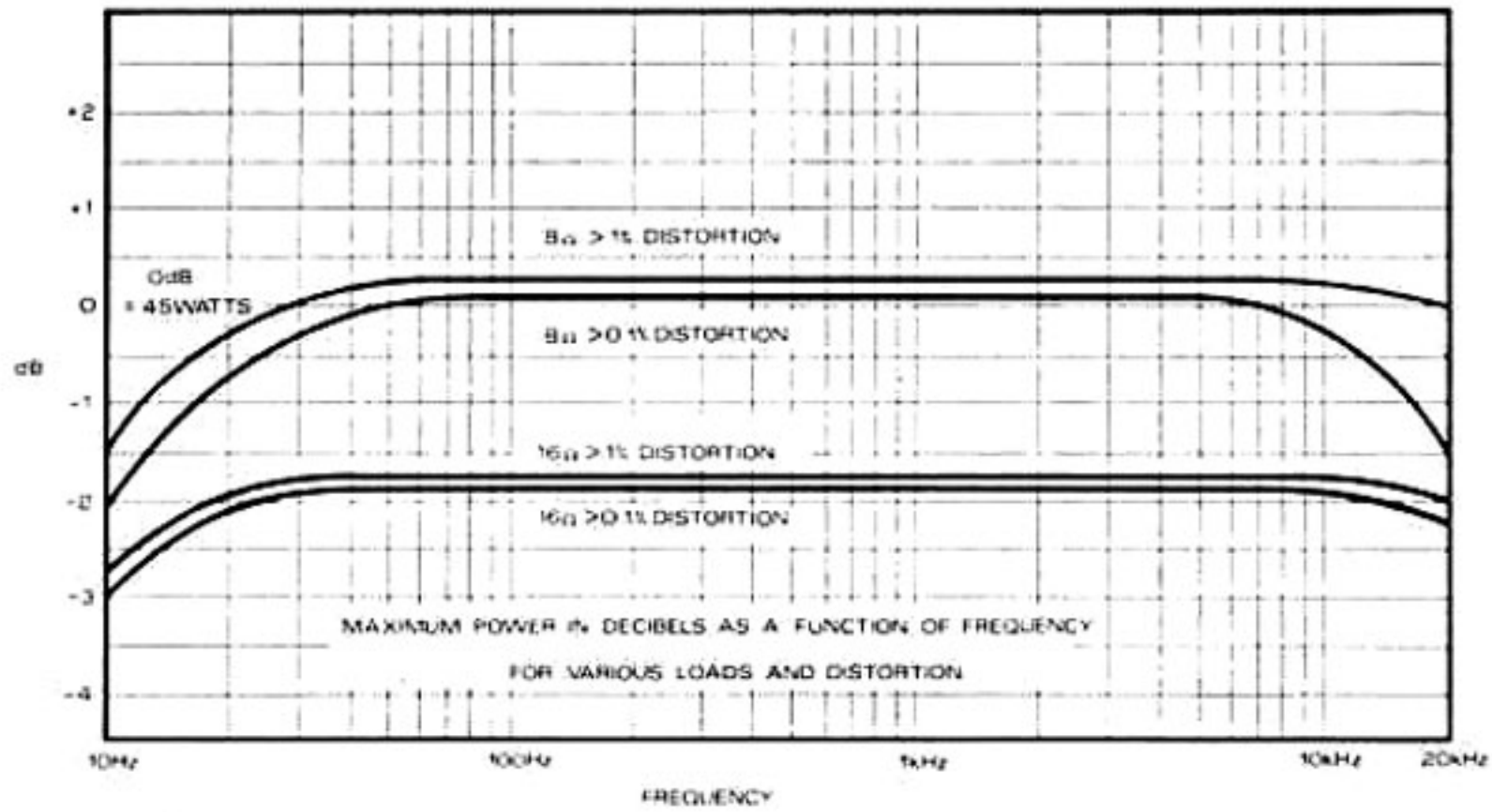

QUAD 303 PERFORMANCE CURVES

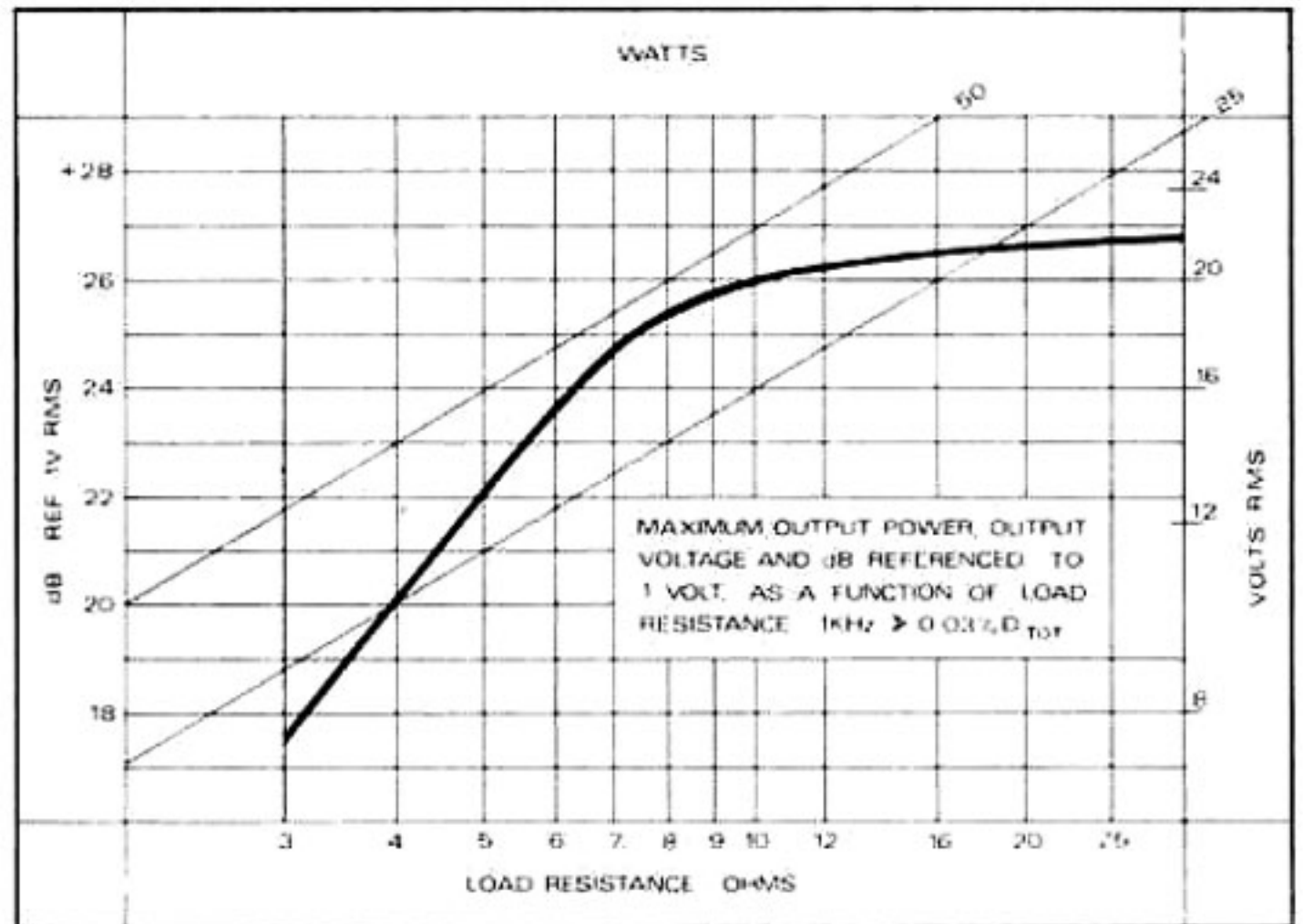

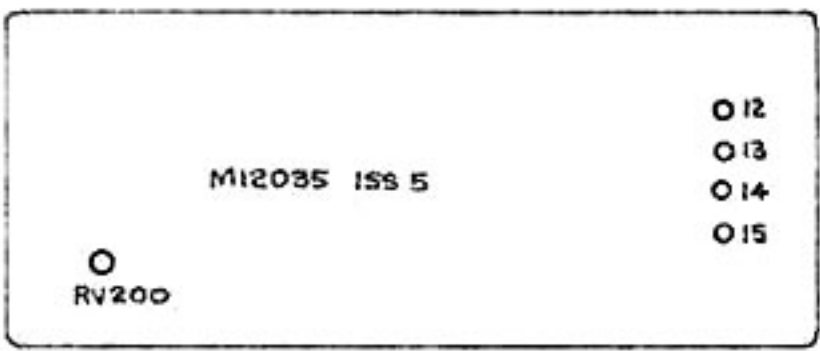
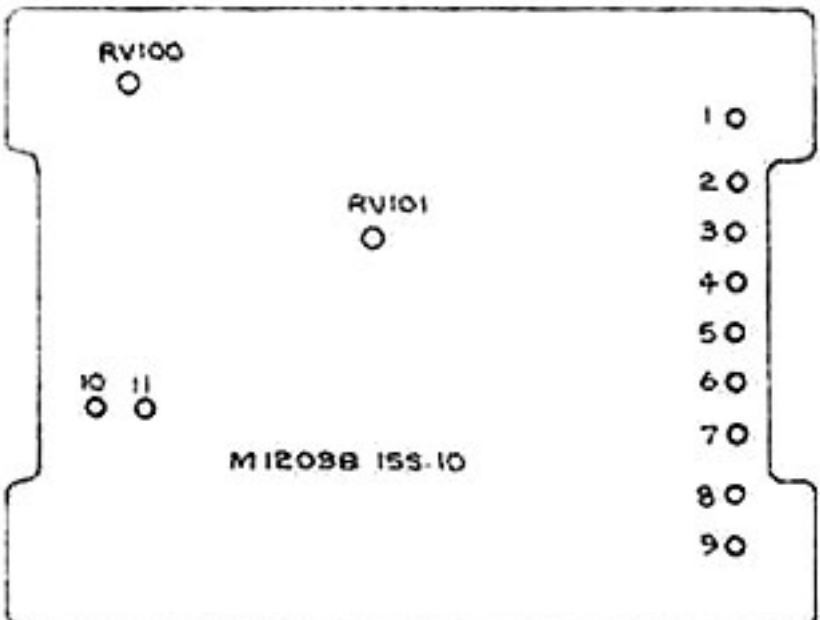
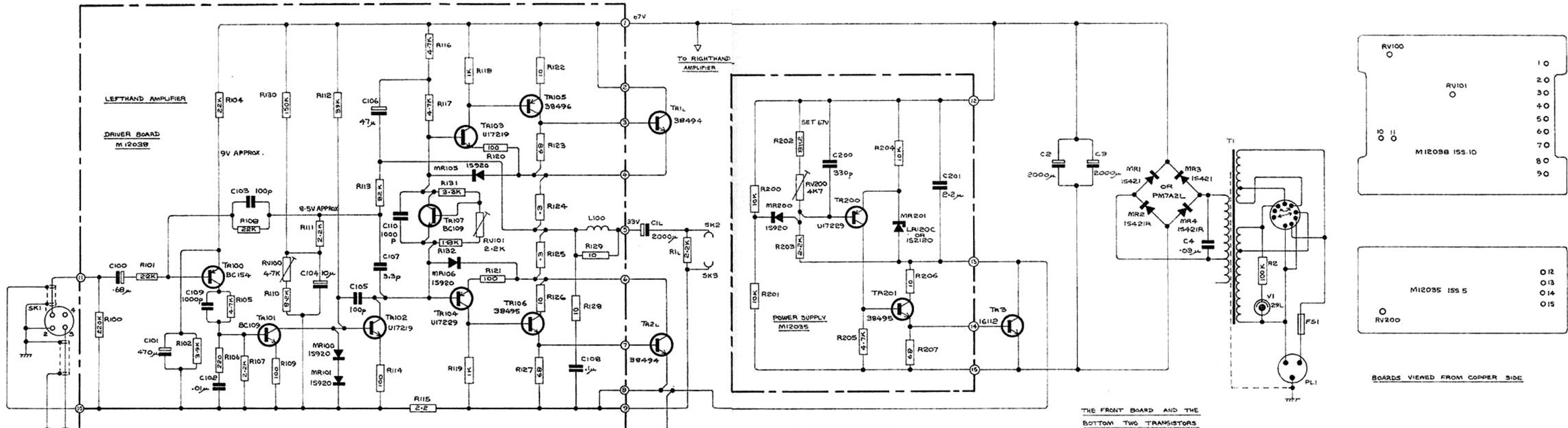

BOARDS VIEWED FROM COPPER SIDE

ALTERNATIVE TRANSISTOR TYPES
 BC154 - BC214C
 U17219 - ZTX304, MPS.A06
 E5457, BC682
 U17229 - ZTX504, MPS.A56
 E5459

THE RIGHTHAND AMPLIFIER IS IDENTICAL TO THE LEFTHAND AMPLIFIER

THE FRONT BOARD AND THE BOTTOM TWO TRANSISTORS ON THE HEAT SINK ARE THE LEFTHAND CHANNEL

ISSUE	DATE	MODIFICATION	Drawn	Rcm	3-9-70
No 2	4-9-70	REDRAWN	Traced	Rcm	3-9-70
No 3	13-12-73		Checked	JL	4-7-70
			Approved		

QUAD - The Acoustical Mfg Co Ltd Huntingdon England.

QUAD 303
 CIRCUIT DIAGRAM
 (ABOVE SERIAL No 11500)

M12160

